

Ejector Sleeves

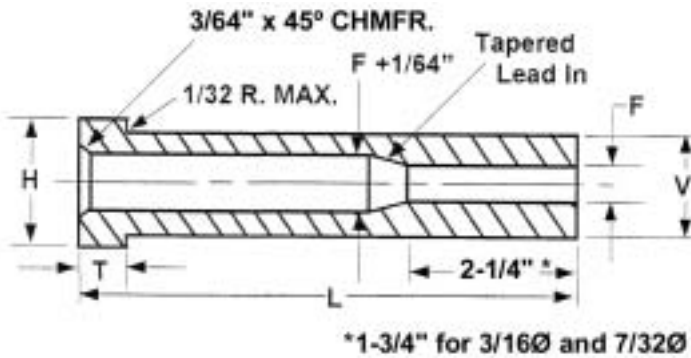

- Constructed from the finest grade hot work die steel.
- Nitrided outside surface for a hardness of 64-75 Rc.
- Ground after nitriding for straightness and finish.
- Bearing diameter is 300 Brinell and is honed concentric with the O.D. of the sleeve.
- Strength and longevity ensured by heads that are hot forged for maximum strength.

Tolerance Table

(V) Sleeve Dia.	(F) Sleeve I.D.	(H) Head Dia.	(T) Head Thick	(L) Length
+0.000" -0.001"	+0.0003" -0.0000"	+0.000" -0.010"	+0.000" -0.002"	+0.031" -0.000"

(V) O.D.	(F) I.D.	(H) Head Dia.	(T) Head Thick	(L) 4"	Price	(L) 5"	Price	(L) 6"	Price	(L) 7"	Price	(L) 8"	Price
3/16	3/32	3/8	3/16	ES187X4	27.70	ES187X5	30.40	ES187X6	32.70	ES187X7	35.65	ES187X8	53.85
13/64	7/64	3/8	3/16	ES203X4	28.20	ES203X5	30.95	ES203X6	32.95	ES203X7	50.75	ES203X8	55.90
7/32	1/8	13/32	3/16	ES218X4	27.00	ES218X5	29.60	ES218X6	32.40	ES218X7	35.20	ES218X8	47.90
1/4	5/32	7/16	3/16	ES250X4	20.60	ES250X5	21.50	ES250X6	23.20	ES250X7	25.50	ES250X8	27.75
5/16	3/16	1/2	1/4	ES312X4	21.05	ES312X5	22.25	ES312X6	24.20	ES312X7	26.45	ES312X8	29.35
11/32	7/32	9/16	1/4	ES343X4	21.45	ES343X5	22.75	ES343X6	24.80	ES343X7	27.30	ES343X8	30.40
3/8	1/4	5/8	1/4	ES375X4	21.60	ES375X5	23.15	ES375X6	25.20	ES375X7	27.70	ES375X8	30.75
7/16	5/16	11/16	1/4	ES437X4	22.25	ES437X5	24.65	ES437X6	26.95	ES437X7	29.75	ES437X8	32.95
1/2	3/8	3/4	1/4	ES500X4	22.65	ES500X5	26.80	ES500X6	29.10	ES500X7	32.30	ES500X8	35.55
5/8	7/16	7/8	1/4	ES625X4	24.20	ES625X5	29.05	ES625X6	34.05	ES625X7	37.05	ES625X8	41.05
11/16	1/2	15/16	1/4	ES687X4	25.40	ES687X5	30.20	ES687X6	35.55	ES687X7	38.60	ES687X8	42.80
3/4	9/16	1	1/4	ES750X4	31.80	ES750X5	34.80	ES750X6	38.15	ES750X7	42.20	ES750X8	46.20
7/8	5/8	1-1/8	1/4	ES875X4	35.95	ES875X5	39.25	ES875X6	43.20	ES875X7	47.05	ES875X8	49.70
1	3/4	1-1/4	1/4	ES1000X4	40.05	ES1000X5	43.80	ES1000X6	47.50	ES1000X7	52.05	ES1000X8	56.05

Ejector Sleeves

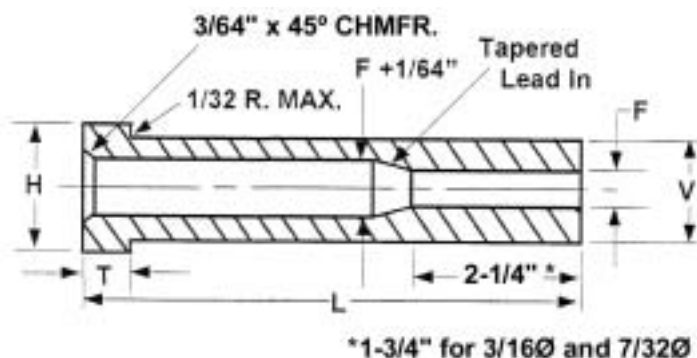

- Constructed from the finest grade hot work die steel.
- Nitrided outside surface for a hardness of 64-75 Rc.
- Ground after nitriding for straightness and finish.
- Bearing diameter is 300 Brinell and is honed concentric with the O.D. of the sleeve.
- Strength and longevity ensured by heads that are hot forged for maximum strength.

Tolerance Table

(V) Sleeve Dia.	(F) Sleeve I.D.	(H) Head Dia.	(T) Head Thick	(L) Length
+0.000" -0.001"	+0.0003" -0.0000"	+0.000" -0.010"	+0.000" -0.002"	+0.031" -0.000"

(V) O.D.	(F) I.D.	(H) Head Dia.	(T) Head Thick	(L) g"	Price	(L) 10"	Price	(L) 11"	Price	(L) 12"	Price	(L) 13"	Price
3/16	3/32	3/8	3/16	ES187X9	73.05	ES187X10	93.50	ES187X11	96.30	---	---	---	---
13/64	7/64	3/8	3/16	ES203X9	73.45	---	---	---	---	---	---	---	---
7/32	1/8	13/32	3/16	ES218X9	67.80	ES218X10	76.50	---	---	---	---	---	---
1/4	5/32	7/16	3/16	ES250X9	31.00	ES250X10	34.75	ES250X11	41.70	ES250X12	42.50	ES250X13	61.65
5/16	3/16	1/2	1/4	ES312X9	32.50	ES312X10	36.00	ES312X11	40.25	ES312X12	44.70	ES312X13	64.00
11/32	7/32	9/16	1/4	ES343X9	34.05	ES343X10	37.45	ES343X11	44.05	ES343X12	47.70	ES343X13	71.60
3/8	1/4	5/8	1/4	ES375X9	34.25	ES375X10	38.10	ES375X11	42.80	ES375X12	47.40	ES375X13	66.75
7/16	5/16	11/16	1/4	ES437X9	36.80	ES437X10	41.05	ES437X11	45.55	ES437X12	50.55	ES437X13	71.60
1/2	3/8	3/4	1/4	ES500X9	39.25	ES500X10	43.80	ES500X11	48.60	ES500X12	53.95	ES500X13	71.00
5/8	7/16	7/8	1/4	ES625X9	44.70	ES625X10	49.20	ES625X11	54.45	ES625X12	59.80	ES625X13	73.00
11/16	1/2	15/16	1/4	ES687X9	47.25	ES687X10	52.00	ES687X11	57.20	ES687X12	62.70	ES687X13	88.00
3/4	9/16	1	1/4	ES750X9	51.05	ES750X10	55.50	ES750X11	60.80	ES750X12	66.00	ES750X13	89.00
7/8	5/8	1-1/8	1/4	ES875X9	56.20	ES875X10	61.30	ES875X11	66.80	ES875X12	71.80	ES875X13	89.50
1	3/4	1-1/4	1/4	ES1000X9	61.40	ES1000X10	66.80	ES1000X11	72.40	ES1000X12	78.45	ES1000X13	97.00

Ejector Sleeves

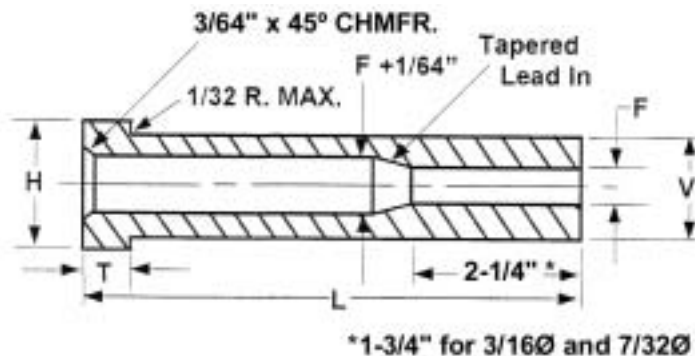

- Constructed from the finest grade hot work die steel.
- Nitrided outside surface for a hardness of 64-75 Rc.
- Ground after nitriding for straightness and finish.
- Bearing diameter is 300 Brinell and is honed concentric with the O.D. of the sleeve.
- Strength and longevity ensured by heads that are hot forged for maximum strength.

Tolerance Table				
(V) Sleeve Dia.	(F) Sleeve I.D.	(H) Head Dia.	(T) Head Thick	(L) Length
+0.000" -0.001"	+0.0003" -0.0000"	+0.000" -0.010"	+0.000" -0.002"	+0.031" -0.000"

(V) O.D.	(F) I.D.	(H) Head Dia.	(T) Head Thick	(L) 14"	Price	(L) 15"	Price	(L) 16"	Price	(L) 17"	Price	(L) 18"	Price
1/4	5/32	7/16	3/16	ES250X14	66.75	ES250X15	74.25	ES250X16	82.50	ES250X17	91.65	ES250X18	101.75
5/16	3/16	1/2	1/4	ES312X14	70.90	ES312X15	78.80	ES312X16	87.75	ES312X17	97.50	ES312X18	108.25
11/32	7/32	9/16	1/4	ES343X14	78.00	ES343X15	86.75	ES343X16	96.30	ES343X17	107.00	ES343X18	118.90
3/8	1/4	5/8	1/4	ES375X14	72.20	ES375X15	80.25	ES375X16	89.25	ES375X17	99.25	ES375X18	110.25
7/16	5/16	11/16	1/4	ES437X14	78.00	ES437X15	86.75	ES437X16	96.30	ES437X17	107.00	ES437X18	118.90
1/2	3/8	3/4	1/4	ES500X14	75.00	ES500X15	83.50	ES500X16	92.75	ES500X17	102.90	ES500X18	114.50
5/8	7/16	7/8	1/4	ES625X14	79.35	ES625X15	88.25	ES625X16	98.00	ES625X17	108.90	ES625X18	120.95
11/16	1/2	15/16	1/4	ES687X14	93.00	ES687X15	103.40	ES687X16	114.90	ES687X17	127.75	ES687X18	141.75
3/4	9/16	1	1/4	ES750X14	94.00	ES750X15	104.50	ES750X16	116.25	ES750X17	128.95	ES750X18	143.50
7/8	5/8	1-1/8	1/4	ES875X14	94.50	ES875X15	105.00	ES875X16	116.75	ES875X17	129.75	ES875X18	144.25
1	3/4	1-1/4	1/4	ES1000X14	99.00	ES1000X15	110.00	ES1000X16	122.50	ES1000X17	135.90	ES1000X18	150.90